



PS8330 Dual-mode DisplayPort™ 1.2 Repeater

Signal Conditioner and Redriver for Dual-mode DisplayPort 1.2 Source Outputs

Product Brief

PS8330

KEY FEATURES

- Compliant to the VESA DisplayPort™ 1.2 Specification
- Supports 5.4Gb/s (HBR2), 2.7Gb/s, and 1.62Gb/s link rates
- Field proven AUX interception (snooping) technology
- Supports Source Feed Forward Equalizer (FFE) with Post Cursor 2 in addition to the 4 pre-emphasis output levels
- Supports 1Mb/s AUX and 720Mb/s Fast AUX (FAUX) transactions with compliant eye diagrams
- Supports DisplayPort and HDMI™/DVI dual-mode output
- Automatic power management
- ESD performance 8kV Human Body Model (HBM)
- Supply Voltage options
 - PS8330A: Dual supplies, 1.5V & 3.3V, low power
 - PS8330B: Single 3.3V Supply
- Package Options
 - 48-pin 7x7mm QFN
 - 40-pin 5x5mm TQFN

APPLICATIONS

- PC Desktop and Notebook Motherboards
- Notebook Docking Stations
- Graphics Cards

GENERAL DESCRIPTION

The PS8330 is a 1-to-1 DisplayPort version 1.2 repeater, or redriver, that supports dual-mode DisplayPort operation. It removes signal loss resulting from internal system distribution through use of an automatic equalizer. A clean, compliant DisplayPort output is regenerated by output drivers. Like the field-proven PS8121ED and PS8311 DisplayPort 1.1a repeaters, the PS8330 uses AUX channel interception, or snooping, that enables it to respond to cable drive requirements indicated by the sink device during link training. The device supports both I2C and pin enabled control options and supports automated source system compliance testing.

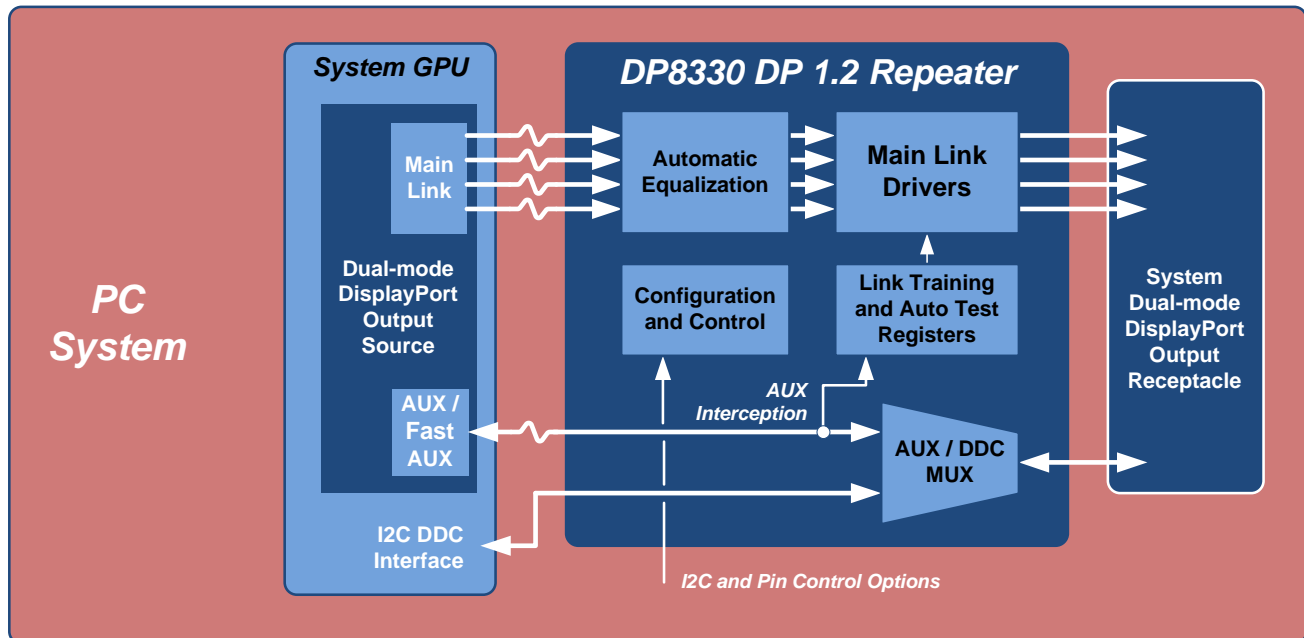

Information furnished by Parade Technologies is believed to be accurate and reliable. However, no responsibility is assumed by Parade Technologies for its use, nor for any infringements of patents or other rights of third parties that may result from its use. Specification is subject to change without notice. No license is granted by implication or otherwise under any patent or patent rights of Parade Technologies. Trademarks and registered trademarks are the property of their respective owners.

Parade Technologies, Inc.
2890 Zanker Road, Suite 102
San Jose, CA 95134, U.S.A.
TEL: 408-329-5540 FAX: 408-329-5541
<http://www.paradetech.com>

© 2011 Parade Technologies, Inc.
All rights reserved.

Rev. 0 Jan 2011