



Embedded DisplayPort™ (eDP™) to LVDS Converter

1 Lane eDP Input, Single Link LVDS Output

Product Brief

PS8612

KEY FEATURES

- Enables the use of LVDS display panels with eDP™ or DisplayPort™ video Source devices
- Supports up to 1680x1050@60Hz at 18-bit color depth or 1440x900@60Hz at 24 bit color depth
- No external crystal or timing reference needed with Parade's CrystalFree™ technology
- Single 3.3V or 2.5V supply with low power consumption, less than 200mW in typical applications
- **DisplayPort Input**
 - Compliant to VESA DisplayPort™ Specification 1.1a
 - Compliant to VESA Embedded DisplayPort (eDP™) Specification 1.2 with AUX enabled backlight control
 - Supports 1-lane main link configuration
 - Link rates of 1.62 Gbps and 2.7Gbps
 - Supports full link training, fast link training, and no link training
 - Supports all eDP display authentication and GPU specific power management protocols (no HDCP support)
- **LVDS Interface**
 - Single link LVDS output, clock speed up to 135MHz
 - LVDS spread spectrum clocking of +/-0.5% and +/-1%
 - Supports LCD panel power sequence control
- Firmware-less operation, supports hardware pin configuration or initial code configuration
- Optional I2C slave interface for chip control
- ESD: HBM 8kV at connector pins
- 0°C to 70°C Operating Temperature Range
- 48-pin Halogen free QFN RoHS package

APPLICATIONS

- Portable PC systems with LVDS display panel
- All-In-One PC systems

GENERAL DESCRIPTION

The PS8612 is an Embedded DisplayPort™ (eDP™) to LVDS converter designed for PC's that utilize a GPU with a DisplayPort™ (DP) or Embedded DisplayPort (eDP™) output and a display panel that accepts an LVDS input. The PS8612 will appear as a DP or eDP Sink device to the video Source, and will serve as an LVDS Source device to the LVDS display panel. The device is a fully integrated solution requiring no external CPU, memory, clock reference or voltage regulator.

The PS8612 can be configured to read EDID from the display DDC channel, or from an option external ROM attached to the PS8612 (I2C master provided). The external ROM can also include configuration code to customize device operation and interface timing.

The PS8612 provides display panel power-up sequencing and backlight control including PWM generation. Backlight characteristics can be controlled by the video Source over the DP AUX channel using the eDP v1.2 DPCD control registers. Alternately, the video Source can provide the backlight control signals to the PS8612 which will gate them for panel power up sequencing, or the Source can bypass the device and control the panel backlight directly.

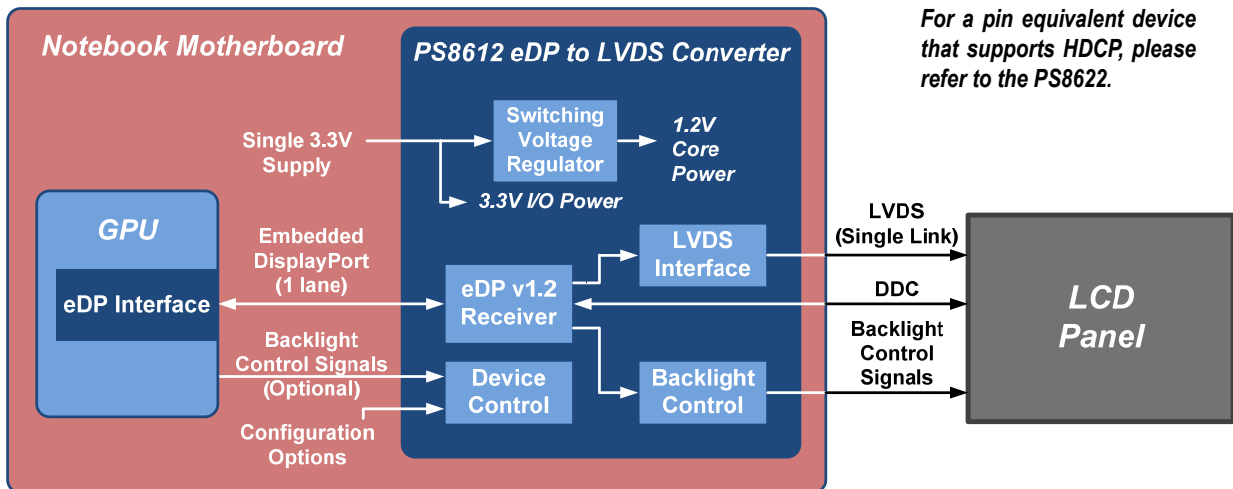

Information furnished by Parade Technologies is believed to be accurate and reliable. However, no responsibility is assumed by Parade Technologies for its use, nor for any infringements of patents or other rights of third parties that may result from its use. Specification is subject to change without notice. No license is granted by implication or otherwise under any patent or patent rights of Parade Technologies. Trademarks and registered trademarks are the property of their respective owners.

Parade Technologies, Inc.
2890 Zanker Road, Suite 102, San Jose, CA 95134
TEL: 408-329-5540 FAX: 408-329-5541
<http://www.paradetech.com>

© 2011 Parade Technologies, Inc.
All rights reserved.

Rev. 2 Mar 2011