



**KEY FEATURES**

- Programmable Receiver Equalization to Compensate Cable Loss
- Up to 15-dB for 1.65 Gbps and 17-dB for 2.25 Gbps Equalization Setting
- Integrated 50-ohm Active Receiver Termination
- Compliance with TMDs Electrical Specification up to 2.7 Gbps
- HDMI 1.3a compliant up to 2.25Gbps.
- DC or AC coupling Receiver up to 2.7 Gbps, capable of supporting DisplayPort 2.7 Gbps
- Support UXGA, WUXGA, & 1080p with 8/10/12 bit deep color
- Built-in Side-band Signals Multiplexer with 5V tolerance for SDAx/SCLx pins
- I2C interface for flexible host control and GPIO saving.
- EDID bridging function for lower system BOM cost
- 5 operation modes with optional I2C Control and EDID Bridge features
- Pin-to-pin compatible to PS301 with CEXT external capacitor for voltage regulation
- Single 3.3V Power Supply, 80-pin TQFP RoHS Package
- 0°C to 70°C Operating Temperature Range
- ESD: Human Body Mode at 8 kV for all inputs, Machine Mode at 400 V, and Charged Device Mode at 2 kV

**APPLICATIONS**

- Digital TV
- Digital Set-Top-Box
- A/V Receiver
- Digital DVR
- 3-to-1 or 2-to-1 HDMI/DVI Switch Box

**GENERAL DESCRIPTION**

PS321/PS221 is a consequent derivative of PS301/PS201, integrated 3-to-1, 2-to-1 HDMI/DVI switch to simplify system level design and reduce system level cost for applications requiring multiple HDMI/DVI input connectors and single output device in digital TV and other emerging digital appliances. Compared with PS301, it integrates 5 operation modes with optional I2C Control and EDID Bridge features.

TMDs inputs and corresponding I2C and HPD connection are selected by S1, S2, & S3(PS321 only) pins or by I2C control. I2C control pins are bi-directional and HPD control pins are uni-directional, SDAx/SCLx and HPD\_SINK are 5V tolerant I/O. Each TMDs channel can support data rate up to 2.7 Gbps with flexible cable equalization up to 16 dB. By supporting both DC and AC coupling, PS321/PS221 also enable DisplayPort (2.7 or 1.62 Gbps) switching function.

**FUNCTIONAL BLOCK DIAGRAM**

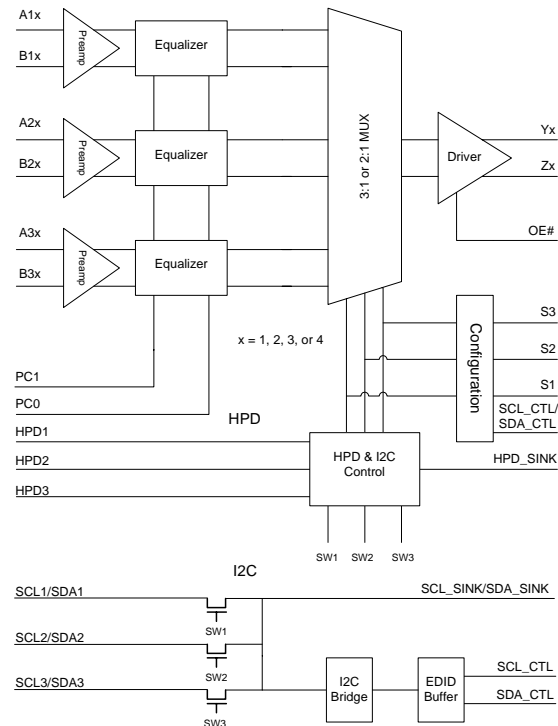

Receiver inputs are terminated with integrated active 50 Ω resistors connected to AVCC. The output is at high impedance state when OE# input is set at high state. PS321/PS221 provides flexible power management with power down and power saving modes.

The PS321/PS221 supports either fixed cable equalization with default setting of 10-dB at 1.65Gbps and 12-dB at 2.25Gbps receiver equalization, or programmable equalization from 0 to 15-dB/17-dB (1.65Gbps/2.25Gbps) by pin selection or I2C control registers.

Rev.0

Information furnished by Parade Technologies is believed to be accurate and reliable. However, no responsibility is assumed by Parade Technologies for its use, nor for any infringements of patents or other rights of third parties that may result from its use. Specification is subject to change without notice. No license is granted by implication or otherwise under any patent or patent rights of Parade Technologies. Trademarks and registered trademarks are the property of their respective owners.

**Date of release: Mar. 2007**

530 Lakeside Dr. Suite 230, Sunnyvale, CA 94085, U.S.A.

TEL: 408-329-5540 FAX: 408-329-5541

<http://www.paradetech.com> © 2007 Parade Technologies, Inc. All rights reserved.