

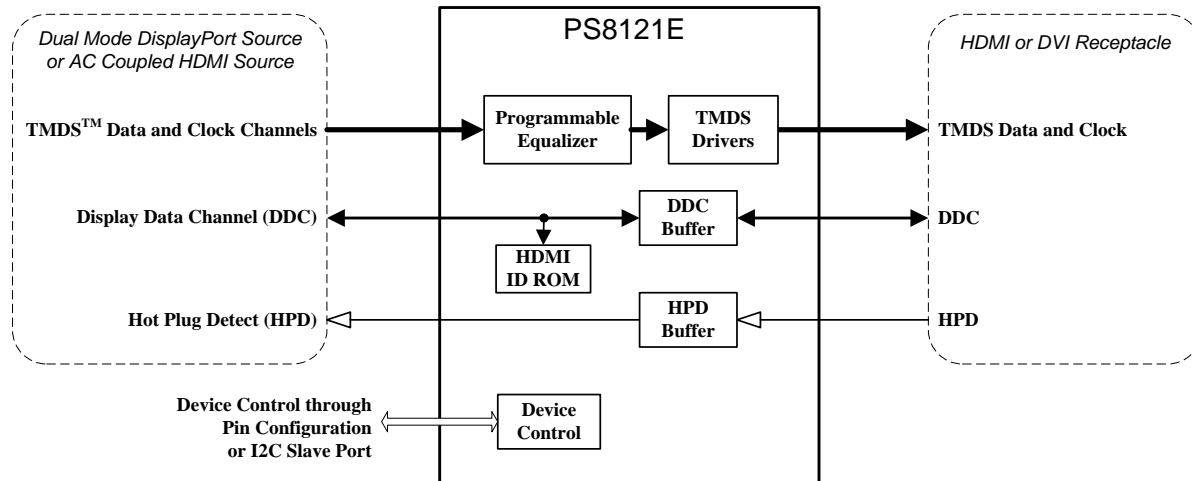

PS8121E Level Translator for Dual Mode DisplayPort™ to DVI/HDMI™ Cable Adapters

Product Brief

PS8121E



KEY FEATURES

- Converts AC coupled HDMI™ or DVI signals into spec compliant DC coupled HDMI or DVI signals
- Ideal for dual mode DisplayPort™ to HDMI/DV cable adapter products
- Pin selectable HDMI or DVI mode (provides HDMI ID at DDC address 0x80)
- Compliant to DisplayPort Interoperability Guideline
- Compliant to HDMI 1.4a specification with up to 2.25Gbps data rate
- Low 500mW consumption enables powering from DisplayPort connection only
- Programmable receiver equalization adjustment to compensate for PCB and/or connector losses in the input signal path
- Integrated 50Ω input termination
- Low Intra-pair and Inter-pair skew
- Built-in, bi-directional DDC active buffer with 5V tolerant interface
- Pin configurable, or I2C control option for increased flexibility and configuration
- Single 3.3V Power Supply
- 48-pin 7x7mm QFN RoHS Package
- 0°C to 70°C Operating Temperature Range
- ESD: Human Body Mode at 8kV

GENERAL DESCRIPTION

The PS8121E is a fully integrated AC to DC level shifter designed for HDMI™ and DVI transmission applications. Although it can serve in multiple applications, the device is ideal for DisplayPort level-shifting cable adapter (or “dongle”) devices. It can be configured specifically for a dual mode DisplayPort to HDMI cable adapter, or a dual mode DisplayPort to DVI cable adapter. By consuming only 500mW, it can be powered directly by the DisplayPort input connection, so no other external power supply is needed. Device operation can be adjusted through pin configuration as required for the application. Increased flexibility is possible through the optional I2C device control input when the device is used within a system that includes a host CPU. The PS8121E includes 50Ω input termination for the TMDs inputs and a programmable (and pin configurable) input equalizer to optimize performance for a given input channel condition. An internal bandgap reference is provided to ensure precise output amplitude control and input termination resistance. The PS8121E operates from a single 3.3V power supply and includes 5V tolerant DDC connections.

APPLICATIONS

- Dual Mode DisplayPort to HDMI Cable Adapter
- Dual Mode DisplayPort to DVI Cable Adapter
- Format conversion on PC mother board or graphics card
- Format conversion within Notebook PC Docking Station
- AC-to-DC converter PHY for embedded HDMI/DVI transmitters
- DVD Players or Set-top boxes

Rev. 2

Information furnished by Parade Technologies is believed to be accurate and reliable. However, no responsibility is assumed by Parade Technologies for its use, nor for any infringements of patents or other rights of third parties that may result from its use. Specification is subject to change without notice. No license is granted by implication or otherwise under any patent or patent rights of Parade Technologies. Trademarks and registered trademarks are the property of their respective owners.

Date of release: Oct 2011

Parade Technologies, Inc.
2890 Zanker Road, Suite 102, San Jose, CA 95134 U.S.A.
TEL: 408-329-5540 FAX: 408-329-5541
<http://www.paradetech.com>
© 2011 Parade Technologies, Inc. All rights reserved.